

# TECNA®

- Italy

## ALATISTHERM



70284 – STANDARDNA  
PEDALA

STABILNI PUNKT APARATI , VODOM  
HLADENI SA PNEUMATSKOM PEDALOM  
,LINEARNIM VOĐENJEM ELEKTRODE ,  
ZA TAČKASTO / PROJEKCIONO –  
POSREDNO - BRADAVIČASTO  
ZAVARIVANJE  
63 – 160 KVA

**ALATISTHERM D.O.O**

Koče Kapetana 25

35230 Čuprija , Srbija

Tel/fax : + 381 (0) 35 8471- 196

Mob 1 : + 381 (0) 65 2771- 802

Mob 2 : + 381 (0) 65 8410- 651

[office@alathetherm.in.rs](mailto:office@alathetherm.in.rs)

[office@alathetherm.co.rs](mailto:office@alathetherm.co.rs)

[www.alathetherm.co.rs](http://www.alathetherm.co.rs)

8211N – 80 KVA – Tačkasto

8212N – 100 KVA – Tačkasto

8213N – 125 KVA – Tačkasto

8201N – 63 KVA – Tačkasto / Projekciono

8202N – 80 KVA – Tačkasto / Projekciono

8203N – 100 KVA – Tačkasto / Projekciono

8204N – 125 KVA – Tačkasto / Projekciono

8206N – 63 KVA – Tačkasto / Projekciono

8207N – 80 KVA – Tačkasto / Projekciono

8208N – 100 KVA – Tačkasto / Projekciono

8209N – 125 KVA – Tačkasto / Projekciono

8214N – 160 KVA – Tačkasto / Projekciono

Mogu da zavaruju I aluminijum Al.

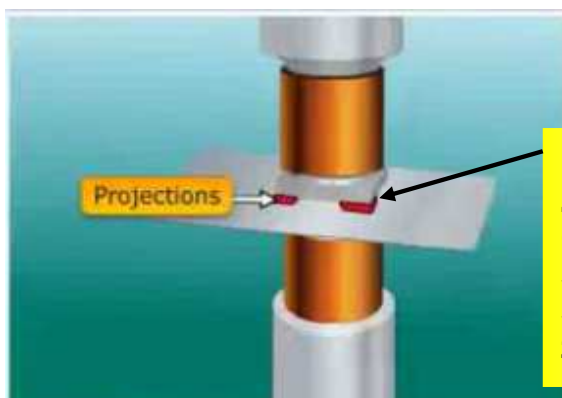

**PROJEKCIONO –BRADAVIČASTO  
ZAVARIVANJE**

Gornja elektroda ne dodiruje mesto spajanja već se  
spajanje vrši posredno preko gornjeg elementa –  
spajanje je na liniji dodira dva elementa koji se  
zavaruju.

- Modularni dizajn mehaničke structure , ruku , cilindra.
- Cilindar sa hromiranim “ Cr “ klipom sa veoma dugim radnim vekom.
- Podesivi anti – rotacioni dodatak.
- Bezuljne pneumatske komponente.
- Glava za spuštanje bez pritiska za servisiranje I podešavanje.
- Cilindar duplog hoda sa osnovnom kontrolom 736 daN.
- Ugrađen filter komprimovanog vazduha.
- Dodatak za diskonektovanje komprimovanog vazduha.
- Vodom hlađeni trafo , ploče, ruke , elektrode.
- Trafo zaštićen epoksi smolom sa dugim vekom trajanja.
- Ventili za kontrolu brzine hoda, amortizeri za kraj zamaha – hoda elektroda.
- Dvofazna kontrola preko papučiće.
- Predpodešavanje drugog programa zavarivanja – za drugu pedalu.
- Mogućnost priključenja dodatne pedale 70379 – uslučaju da imamo dva različita zavarivanja na jednom istom komadu – zavarivanje po drugom programu tj parametrima
- Kontrolna mikroprocesorska jedinica TE550.
- Sinhronizovani SCR prekidač .
- STOP dugme za hitno prekidanje rada.
- Mogu da zavaruju I aluminijum Al.
- 

#### V.P CENE UREĐAJA 8201N do 8214N – Cene nisu konačne

8201N	Single-phase spot and projection welding machine 63 kVA, electrodes depth 390mm, projection plates depth 270mm - Supplied equipped with two-hand control on pedestal - with TE550 control unit	€ 13.660,00
8202N	Single-phase spot and projection welding machine 80 kVA, electrodes depth 390mm, projection plates depth 270mm - Supplied equipped with two-hand control on pedestal - with TE550 control unit	€ 14.280,00
8203N	Single-phase spot and projection welding machine 100 kVA, electrodes depth 390mm, projection plates depth 270mm - Supplied equipped with two-hand control on pedestal - with TE550 control unit	€ 14.840,00
8204N	Single-phase spot and projection welding machine 125 kVA, electrodes depth 390mm, projection plates depth 270mm - Supplied equipped with two-hand control on pedestal - with TE550 control unit	€ 15.840,00
8206N	Single-phase spot and projection welding machine 63 kVA, electrodes depth 540mm, projection plates depth 420mm - Supplied equipped with two-hand control on pedestal - with TE550 control unit	€ 14.240,00
8207N	Single-phase spot and projection welding machine 80 kVA, electrodes depth 540mm, projection plates depth 420mm - Supplied equipped with two-hand control on pedestal - with TE550 control unit	€ 14.840,00
8208N	Single-phase spot and projection welding machine 100 kVA, electrodes depth 540mm, projection plates depth 420mm - Supplied equipped with two-hand control on pedestal - with TE550 control unit	€ 15.410,00
8209N	Single-phase spot and projection welding machine 125 kVA, electrodes depth 540mm, projection plates depth 420mm - Supplied equipped with two-hand control on pedestal - with TE550 control unit	€ 16.410,00
8211N	Single-phase spot welding machine 80 kVA, electrodes depth 800 mm, with TE550 control unit	€ 16.480,00
8212N	Single-phase spot welding machine 100 kVA, electrodes depth 800 mm, with TE550 control unit	€ 17.510,00
8213N	Single-phase spot welding machine 125 kVA, electrodes depth 800 mm, with TE550 control unit	€ 18.250,00
8214N	Single-phase spot and projection welding machine 160 kVA, electrodes depth 390mm, projection plates depth 270mm - Supplied equipped with two-hand control on pedestal - with TE550 control unit	€ 16.650,00

## KONTROLNA JEDINICA TE550 / TE550+ 50200+50097



**TE550 - TE550 + 50200 + 50097**

**NAPOMENA : TECNA ne proizvodi rashladne jedinice i kompresore. Ove elemente nabavljate sami prema potrebnim protocima**

### MOGUĆNOSTI , STANDARDNE , DODATNE - optional I NEDOSTUPNE – notavailable za kontrolne jedinice

	<b>TE550</b>	<b>TE550 + 50200 + 50097</b>
Amperometro - Ammeter - Ampèremètre - Amperemeter - Amperimetro	●	●
N° parametri - Parameters No. - Nb. paramètres Nr. Parameter - N° parametros	<b>26</b>	<b>26</b>
N° programmi - Programs No. - Nb. Programmes - Nr. Programme - N° de programas	<b>250</b>	<b>250</b>
Interfaccia RS232/RS485 - RS232/RS485 Interface - Interface RS232/RS485 Serielle Schnittstelle RS232/RS485 - Interfase RS232/RS485	○	○
Corrente costante - Constant current - Courant constant - Konstantstrom - Corriente constante	●	●
Tempo di saldatura a semi-periodo - Half-cycle welding time - Temps de soudage à demi-periode Schweisszeit in Halbwellen - Tiempo de soldadura en semi-periodos	●	●
Funzione incrementale - Stepper function - Fonction d'incrémentation Inkrementalfunktion - Función incremental	●	●
Energia costante - Constant energy - Energie constante - Konstantenergie - Energia costante	—	●
Contatore delle saldature - Welds counter - Compteur de soudures Zähler Schweissungen - Contador de la soldadura	●	●
Programmazione del numero massimo di saldature da eseguire - Maximum welds to be carried out adjustment Réglage du nombre maximum de soudages à exécuter - Programmierung Anzahl max. Schweissungen Programación del número máximo de soldadura a efectuar	●	●
Ingresso bicomando - Two hands input - Entrée bicommande Eingang Zweihandauslösung - Entrada del mando bimanual	●	●
Uscite di fine ciclo/interblocco - End of cycle/interlock outputs - Sorties de fin de cycle/interbloque Signal Zyklusende/Verriegelung - Salida fin do ciclo (discriminador)	●	●
Limiti superiore ed inferiore di corrente - Higher and lower current limits Limites supérieures et inférieures de courant - Obere und untere Stromlimits Limites superior e inferior de la corriente	●	●
Uscita di segnalazione di saldatura fuori limiti - Output signal for out-of-limits spots Sortie de signalisation de point hors limites par relais - Signalausgang Schweissungen ausser Limit Salida de señalización de soldaduras fuera de limites	●	●

● Standard    ○ Opzionale. Optional. Option. Opción.    — Non disponibile. Not available. Non disponible. Nicht verfügbar. No disponible.

**70320 – Sigurnosna kontrola za dve ruke na postolju , podesive visine . Preporučljivo za sigurnost samog operatera već prema radnim uslovima. Za Projekcione uređaje – standardna oprema. Za Tačkaste uređaje opciono – dodatno-**



**50214 ( RS232) ili 50209 (RS485) – INTERFEJS za mrežno povezivanje uređaja – opciono - dodatno**



**ALATISTHERM D.O.O**  
Koče Kapetana 25  
35230 Čuprija , Srbija  
Tel/fax : + 381 (0) 35 8471- 196  
Mob 1 : + 381 (0) 65 2771- 802  
Mob 1 : + 381 (0) 65 8410- 651  
[office@alatistherm.in.rs](mailto:office@alatistherm.in.rs)  
[office@alatistherm.co.rs](mailto:office@alatistherm.co.rs)  
[www.alatistherm.co.rs](http://www.alatistherm.co.rs)

**PEDALA 70379 – za 8201N do 8209N.  
PEDALA 70462 – za 8211N do 8214N  
opciono - dodatno**



**PEDALA 8234 - kontrola duplog hoda – samo za tačkasto zavarivanje – opciono - dodatno**



**Art. / Item 8234**

**8230 – Ventil koji zaustavlja cirkulaciju vode ( rashladne tečnosti ) kada se uređaj isključi sa dodatnim elementom koji zaustavlja zavarivanje ako nema cirkulacije. – opciono - dodatno**



**8232 – Birač sa potenciometrom – za pozivanje zavarivačkih programa. – opciono - dodatno**



**8235 – Cilindar 1242 daN ( Fi 125 duplog hoda. Ukupan hod 100 mm. Dupli hod 60 + 40. Samo za uređaje koji rade Tačkasto / Projekciono. – opciono - dodatno**



**8236 – Podešavač duplog hoda za cilindar 736 daN , 0 – 80 mm .**

**8237 – Podešavač duplog hoda za cilindar 1242 daN ( dodatak 8235 ), 0 – 80 mm. opciono - dodatno**



**OBJAŠNJENJE ZA ELEMENTE 8238 + 8239 , opciono - dodatno**

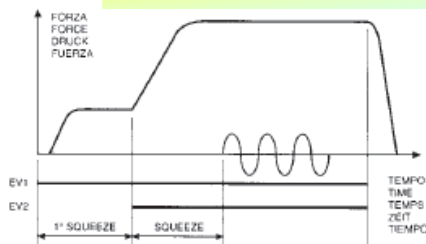

	8238	8239
Accostaggio a bassa forza per cilindro	736 daN	1242 daN
Low pressure squeeze for cylinder	736 daN	1242 daN
Accostage à basse force pour vérin	736 daN	1242 daN
Annäherung bei niedrigem Druck für Zylinder	736 daN	1242 daN
Acercamiento a baja fuerza para cilindros	736 daN	1242 daN



„ A „ – Pomeranje glave bez pritiska

„ B „ – Dupli hod kontrolisan ključem

„ C „ – STOP dugme

### GABARITI – DIMENZIJE UREĐAJA

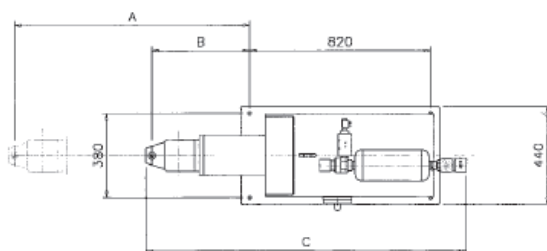
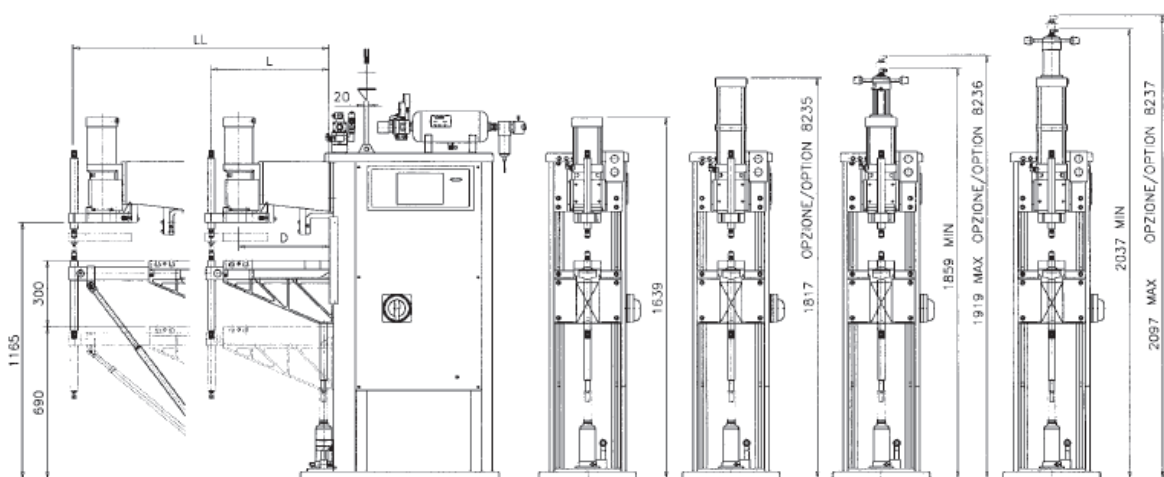

ART. - ITEM	A	B	C	D	L	LL
8201N	--	289	1300	270	390	--
8202N	--	289	1300	270	390	--
8203N	--	289	1300	270	390	--
8204N	--	289	1300	270	390	--
8206N	--	445	1456	420	540	--
8207N	--	445	1456	420	540	--
8208N	--	445	1456	420	540	--
8209N	--	445	1456	420	540	--
8211N	690	--	1700	--	--	800
8212N	690	--	1700	--	--	800
8213N	690	--	1700	--	--	800
8214N	--	289	1300	270	390	--

## DODACI

8230	OPTION valve to stop the water cooling when the machine is off	€ 542,00
8232	OPTION rotary selector for recalling the welding programs	€ 247,00
8234	OPTION double stroke control device with pneumatic foot instead of key	€ 151,00
8235	OPTION cylinder 1242 daN (Ø 125 double stage) total stroke 100mm (for 8201N...09N and 8214N)	€ 874,00
8236	OPTION adjustable double stroke for 736 daN cylinder (standard)	€ 320,00
8237	OPTION adjustable double stroke for 1242 daN cylinder (option item 8235)	€ 320,00
8238	OPTION low force squeeze for 736 daN cylinders (standard)	€ 380,00
8239	OPTION low force squeeze for 1242 daN cylinders (option item 8235)	€ 380,00
8240	OPTION proportional valve	€ 3.130,00

## ELEKTRODE I DODACI ZA UREĐAJ 8201N do 8214N

8701	Straight electrodes (pair)	€ 34,00
8702	Flat electrodes (pair)	€ 60,00
8703	Offset electrodes (pair)	€ 48,00
8704	Oversize flat electrodes (pair)	€ 88,00
8705	Angled electrodes with offset tip (pair)	€ 48,00
8706	Bent electrodes (pair)	€ 113,00
8726	Copper-chromium-zirconium bar diam. 22 L=750 mm	upon demand
70320	Two-hand control on pedestal (standard on projection welders)	€ 502,00
70379	Additional electrical foot control (for 8201N...09N)	€ 189,00
70462	Additional electrical foot control (for 8211N...14N)	€ 194,00
50214	Insulated serial interface RS232 for communication with PC or printer	see control unit kits price list
50209	Insulated serial interface RS485 for communication in a network	see control unit kits price list
50200	TE550 supplementary board for electrodes dressing	see control unit kits price list
50097	TE550 supplementary board to be used together with item 50200 for constant energy	see control unit kits price list



## TEHNIČKI PODACI

ITEM		8201 N	8202 N	8203 N	8204 N	8206 N	8207 N	8208 N	8209 N	8211 N	8212 N	8213 N	8214 N
Tačkasto/ Projekciono		•/•	•/•	•/•	•/•	•/•	•/•	•/•	•/•	•/-	•/-	•/-	•/•
Nominalna snaga na 50%	kVA	63	80	100	125	63	80	100	125	80	100	125	160
Maksimalna snaga	kVA	230	295	420	460	170	230	315	350	135	205	225	650
Struja kratkog spoja	kA	40	44	52	54	29	34	39	41	20	25	26	65
Maksimalna struja za aluminijum Al	kA	36	40	47	49	26	30	35	37	18	22	23	59
Maksimalna struja za čelik - lim	kA	32	35	41	43	20	27	31	32	16	20	20	52
Termička struja 100%	A	6200	6800	7000	8400	6200	6800	7000	8400	6800	7000	8400	9300
Sekundarni napon praznog hoda	V	7.1	8.3	10	10.5	7.1	8.3	10	10.5	8.3	10	10.5	12.1
	V	6.3	7.5	9	9	6.3	7.5	9	9	7.5	9	9	-
	V	5.6	6.7	8	8	5.6	6.7	8	8	6.7	8	8	-
	V	5	6.1	7.1	7.3	5	6.1	7.1	7.3	6.1	7.1	7.3	-
Napojni napon 50Hz *	V	400	400	400	400	400	400	400	400	400	400	400	400
Presk kabla L=30 m	mm <sup>2</sup>	50	70	95	2x50	50	70	95	2x50	70	95	2x50	2x70
Osigurači	A	125	160	200	250	125	160	200	250	160	200	250	315
Minimalno rastojanje ruku	mm	175	175	175	175	175	175	175	175	175	175	175	175
Maksimalno rastojanje ruku	mm	475	475	475	475	475	475	475	475	475	475	475	475
Dubina L	mm	390	390	390	390	540	540	540	540	800	800	800	390
Dubina D	mm	270	270	270	270	420	420	420	420	-	-	-	270





Nivo buke	dB(A)	71	73	76	77	72	72	75	75	76	76	76	78
Merni uslovi													
Radni zamah - hod	mm	50	50	50	50	50	50	50	50	20	20	20	50
Vreme zav.	cycles	13	11	10	12	22	21	17	22	23	16	20	11
Struja zavarivanja	kA	29	34	39	41	22	25	29	30	15	19	20	49
Frekvencija rada	punkt/min	6	6	6	6	6	6	6	6	15	15	15	6
Neto težina (otprilike)	kg	510	525	540	555	530	545	560	575	585	600	615	570

## **ALATISTHERM D.O.O**

**Koče Kapetana 25**

**35230 Čuprija , Srbija**

**Tel/fax : + 381 (0) 35 8471- 196**

**Mob 1 : + 381 (0) 65 2771- 802**

**Mob 2 : + 381 (0) 65 8410- 651**

**[office@alatistherm.in.rs](mailto:office@alatistherm.in.rs)**

**[office@alatistherm.co.rs](mailto:office@alatistherm.co.rs)**

**[www.alatistherm.co.rs](http://www.alatistherm.co.rs)**